

Team Spirit

Strength Through Unity

Right at the official start of the Packaging Machines Business Unit (PA-PM), Demarex SA, Tevopharm BV and Transver AG combined their forces to meet the demands of their customers.

A Chinese proverb says: “The superior man acts before he speaks, and afterwards speaks according to his action” – a quotation perfect for the Packaging Machines Business Unit: right after announcing the creation of the new business unit and acting as a team, a joint

project by Demarex, Tevopharm and Transver was already underway.

Exquisite Biscuits

In the year 1870 the pharmacist Charles Delacre started his own company with the same name „Delacre“. He prescribed chocolate as a remedy for his pharmacy customers and was so successful with it that he opened his first factory in 1891. He already produced at that time ingenious new biscuits at a Patisserie level. Delacre then requested a flexible adaptable packaging solution for his individual fine creative biscuits.

A win-win situation

One or several Delacre cookies are wrapped at a time and then put into boxes with the Flowpack machine. Tevopharm performs the wrapping process and Demarex provides the pick-and-place operation. Transver, a conveying specialist, was the missing link to bring the project to life. Compatible yet stand-alone, the Demarex and Tevopharm machines can interlink directly and feed a Pack-200 with Delfi, or use a Transver

conveyor for a different configuration. In this case, the cookies travel on Transver belts conveyors, pass through Demarex Delfi and the Tevopharm wrapper, return on Transver belts and finally feed into a Demarex Presto Dual Collator. Not only products pass from one machine to the next, data is also exchanged. The Delfi systems provide the Pack-200 with its input rate so the wrapper to adjust its own speed, increasing the line’s efficiency.



Demarex Delfi for feeding wrapper

- 1 Transver TD Conveyor, hygienic, convenient and safe.
- 2 Tevopharm pack-200, the medium speed servo driven flowrapper
- 3 Presto Top Loader for automatic box packing wrapped products.



Tevopharm Pack-200

The modular Pack-200 is a medium speed versatile flow wrapper. It is equipped with a minimum of mechanical parts and has many of the same identical parts of the successful Pack-2000.

The Transver conveyors

Transver is indisputably a conveying systems expert. The compact design of their conveyors allows easy integration. With smooth surfaces and avoidance of nooks and edges, their belts have a long service life under tough working conditions. Transver is the perfect interface for packaging machine modules.

The Demarex Delfi

More than just locating the products to pick, the current Delfi offers a large range of quality controls. With a new vision system based on the latest known algorithms, it is now easy to sort and choose the products to be packaged.

The Demarex Presto Dual Collator

The Demarex flexibility continues. With two independent collating chains, this evolution of the famous Demarex Top Loader offers even more capabilities of integration: merging two separate flows, synchronized or not, is now a standard feature, even with two different products.

PA-PM believe in progress

In close collaboration and by sharing their know-how, the Packaging Machines companies supply solutions combining years of experience and mastery in all packaging application fields. The future development will be driven in this direction to improve the product quality and the services of the Business Unit. As another Chinese Proverb stated: "The whole is more than the sum of its parts."

For more information, please contact:

Dr. Marc-Olivier Demarex

Phone +41 21 644 25 35

marc-olivier.demarex@demarex.com

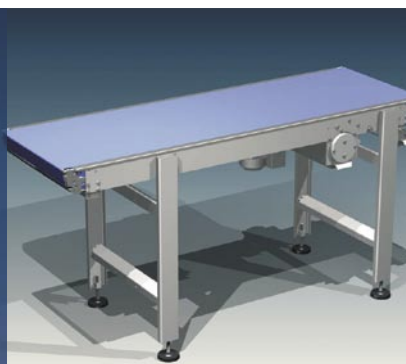

1



2

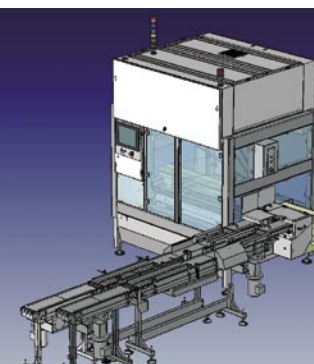

3