



Coffee Dreams from the Dominican Republic

The coffee producer Induban will continue to count on Bosch Packaging Technology. The PMC 4202 BG offers even more production flexibility – at an unbeatable cost-efficiency ratio.

Industrias Banilejas – a traditional family business

With a high market share, the traditional coffee company Industrias Banilejas enjoys an excellent reputation with its customers in the Dominican Republic. Led by “Don Rafael”, the company’s secret to success is based on the integration of the processes. The coffee beans are cultivated on company-owned plantations where 1’200 employees tend to the

coffee production and packaging, dealing with every phase through delivery. Induban coffee can be bought in almost every store in the Dominican Republic.

Modern techniques for a time-tested partnership

Up to now, coffee from Induban was packaged on three reliable Bosch PKS package makers. After twelve years of high customer satisfaction with the tech-

nical aspects and particularly the excellent support supplied by Bosch, Induban once again decided in favor of this trusted partner. Last May 2005 an order was placed to continue reaping the benefits of increased flexibility in day-to-day production: Using the new PMC 4202 BG Induban is able to package ground coffee as well as whole beans while also being convinced of it’s unbeatable cost-efficiency ratio.

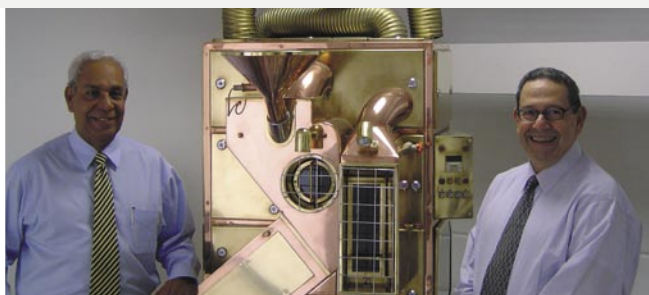

from left to right:
Rafael Portillo, Plant
Manager and Head of
Industrias Banilejas
Rafael Perelló

**Product-conserving packaging
at a high output rate**

Two FVS 3101 SQ auger fillers and one FIW 4011K net weigher are used to package ground coffee or whole beans. The low drop height allows a particularly gentle handling of the product. Due to the compact design of the auger filler FVS and the net weigher FIW a setup with a combination of both on top of one bag-making unit is possible. This offers Industrias Banilejas the benefit of the best dosing technique for whole bean as well as ground coffee. Two parallel bag-making units help yield the high output of the line with up to 95 packages per minute. The flexible PMC 4202 BG manufactures three different sizes of the coffee package with adhesive tape and corner creasing of Induban's choice.

Success based on experience

Industrias Banilejas has been a satisfied Bosch customer for many years and cherishes the close personal relationship with their competent contacts at Bosch as well as the first-rate Bosch support. An example in this context would be the successful conversion of the ex-

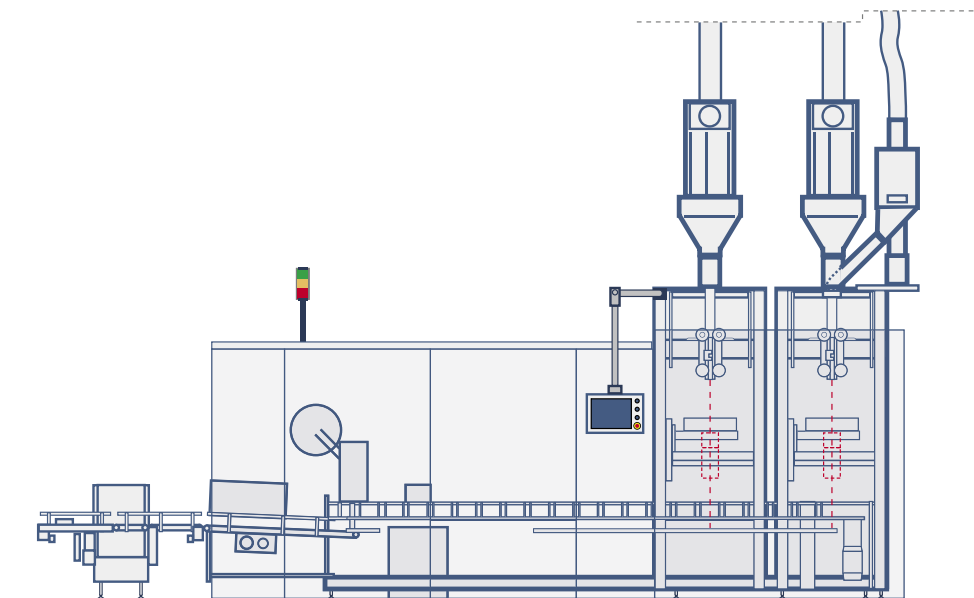

Coffee packaging line consisting of:
1 package maker PMC 4202 BG
2 auger fillers FVS 3101 SQ

1 net weigher FIW 4011 K
1 valve applicator CVA 2000 VIS
1 check weigher KWI 3010 N

isting lines to incorporate a new IPC control system. However, making a decision in favor Bosch was aided by another customer's experience: During a visit to a large German coffee roaster, Induban was able to see a PMC 4202 BG machine in operation and receive a first-hand impression of the production advantages. Convinced by the proven quality, advanced technology, first-class project management and service the transaction

was finalized by a handshake at Interpack in April 2005. Since February 2006 Industrias Banilejas is running the PMC 4202 BG successfully in operation.

For more information please contact:

Martin Kühl

Phone +49(711)811-57480

martin.kuehl@boschpackaging.com

